



SPECIFIC VEHICLE ALARM FITTING INSTRUCTIONS

REV. 00

www.cobra.it

MAKE	JEEP	MOD.	CHEROKEE	YEAR	03 →	PETROL <input type="checkbox"/>	DIESEL <input checked="" type="checkbox"/>
------	-------------	------	-----------------	------	-------------	---------------------------------	--

- | | |
|------------------------------|--|
| ALARM/SIREN POSITION | Position the compact alarms and the sirens behind the air filter box, passenger's side. |
| CENTRAL UNIT POSITION | Position the modular systems and the modules under the dashboard, driver's side. |
| POWER SUPPLY | <p>+30: connect to the PINK wire located in the vertical bundle of cables, on the left of the steering column.</p> <p>-31: connect to an original ground terminal located behind the left lateral bulkhead.</p> |
| IGNITION WIRE | +15/54: connect to the BLUE/PINK wire located in the vertical bundle of cables, on the left of the steering column. |
| DIRECTION INDICATORS | Connect to the GREEN/RED and BROWN/RED wires, in the 60 way grey connector, behind the driver's side sill cover. |
| ELECTRIC WINDOWS | <p>Positive control signal</p> <p>Front window, driver's side:
cut the 1,5 mm² LIGHT BLUE wire.</p> <p>Front window, passenger's side:
cut the 1,5 mm² BROWN wire.</p> <p>Rear window, driver's side:
cut the 1,5 mm² BLUE/WHITE wire.</p> <p>Rear window, passenger's side:
cut the 1,5 mm² GREY/BLACK wire</p> <p>The above mentioned wires are located in the wiring harness coming out of the 14 way grey connector, in the serial push-button panel in the tunnel.</p> |
| CENTRAL DOORS LOCKING | Connect to the PINK/VIOLET wire, position nr.10, in the 42 way green connector, on the back of the central located on the left of the steering column, near the door. Refer to the A section for the Bridge serie; refer to the B section for the 3100, 3900 and Cobra Connex series of the fitting diagram nr. 184. |
| IMMOBILISATION POINT | <p>Ignition locking</p> <p>Cut the YELLOW/RED wire in the wiring harness coming out of the 2 way green connector located on the clutch pedal.</p> |
| STARTER | +50: Cut the YELLOW wire in the wiring harness of the ignition key. |
| BONNET SWITCH | Connect to the BROWN/LIGHT BROWN wire at the position nr.6, in the 26 way grey connector, on the back of the central located on the left of the steering column near the door. |
| DOORS SWITCH | Connect to the LIGHT BROWN wire at the position nr.4 and to the LIGHT BROWN/WHITE wire at the position nr.5, in the 26 way grey connector, on the back of the central located on the left of the steering column, near the door. |
| BOOT SWITCH | Connect to the LIGHT BROWN/BLACK wire at the position nr.7, in the 26 way grey connector, on the back of the central located on the left of the steering column, near the door. |

FITTING DIAGRAM NR. 184

Diagram for lock/unlock of the doors on
JEEP CHEROKEE year 2003

A section

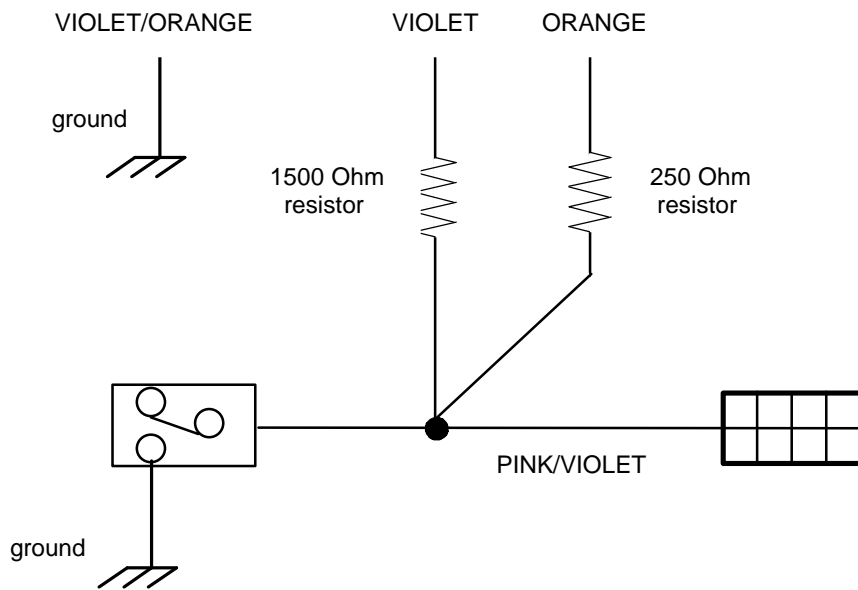

B section

