



CAR SECURITY

SPECIFIC VEHICLE ALARM FITTING INSTRUCTIONS

REV. 00

www.cobra.it

MAKE

CITROEN

MOD.

XSARA 2*

YEAR.

02 →

PETROL
DIESEL

* Models with original equipment keyless entry system.

ALARM/SIREN POSITION

Position the compact alarms and the sirens on the dome of the shock absorber, passenger's side.

CENTRAL UNIT POSITION

Position the modular systems and the modules under the dashboard, driver's side.

POWER SUPPLY

+ **30**: connect to the 3 mm² RED wire located at the entrance of the fuse box.
- **31**: connect with a cable terminal to one of the original ground wire located on the right of the BSI operating central.

IGNITION WIRE

+ **15/54**: connect to the wire, at the position nr. 16, coming out of the 26 way blue connector of the BSI operating central.

DIRECTION INDICATORS

Connect to the wires at the positions nr.13 and nr.14 coming out of a 16 way black connector of the BSI operating central.

ELECTRIC WINDOWS

Positive control signal

Front window, driver's side:

refer to the **diagram nr. 113**.

Front window, passenger's side:

refer to the **diagram nr. 113**.

Rear window, driver's side:

cut the wire located at the position nr. 3, in the 16 way grey connector.

Rear window, passenger's side:

cut the wire located at the position nr. 4, in the 16 way grey connector.

ACTIVAT./DEACTIVATION CONTROLS

Connections antitheft/vehicle

Refer to the **diagram nr. 106**.

IMMOBILISATION POINT

General underlock

Cut the wire located at the position nr. 16 coming out of the 26 way blue connector of the BSI central.

STARTER

+**50**: Cut the YELLOW wire located in a flying wiring harness placed on the rear of the cover of the fuse box.

BONNET SWITCH

Install an additional switch on the front headlamp support plate, driver's side.

DOORS SWITCH

Connect to the wire at the position nr. 18 of the 26 way blue connector of the BSI operating central.

Note: the polarity of the lamp is positive.



CAR SECURITY

SPECIFIC VEHICLE ALARM FITTING INSTRUCTIONS

REV. 00

www.cobra.it

FITTING DIAGRAM N° 106

Diagram for the interfacing of art. 3800 on CITROEN XSARA 2 year 2002

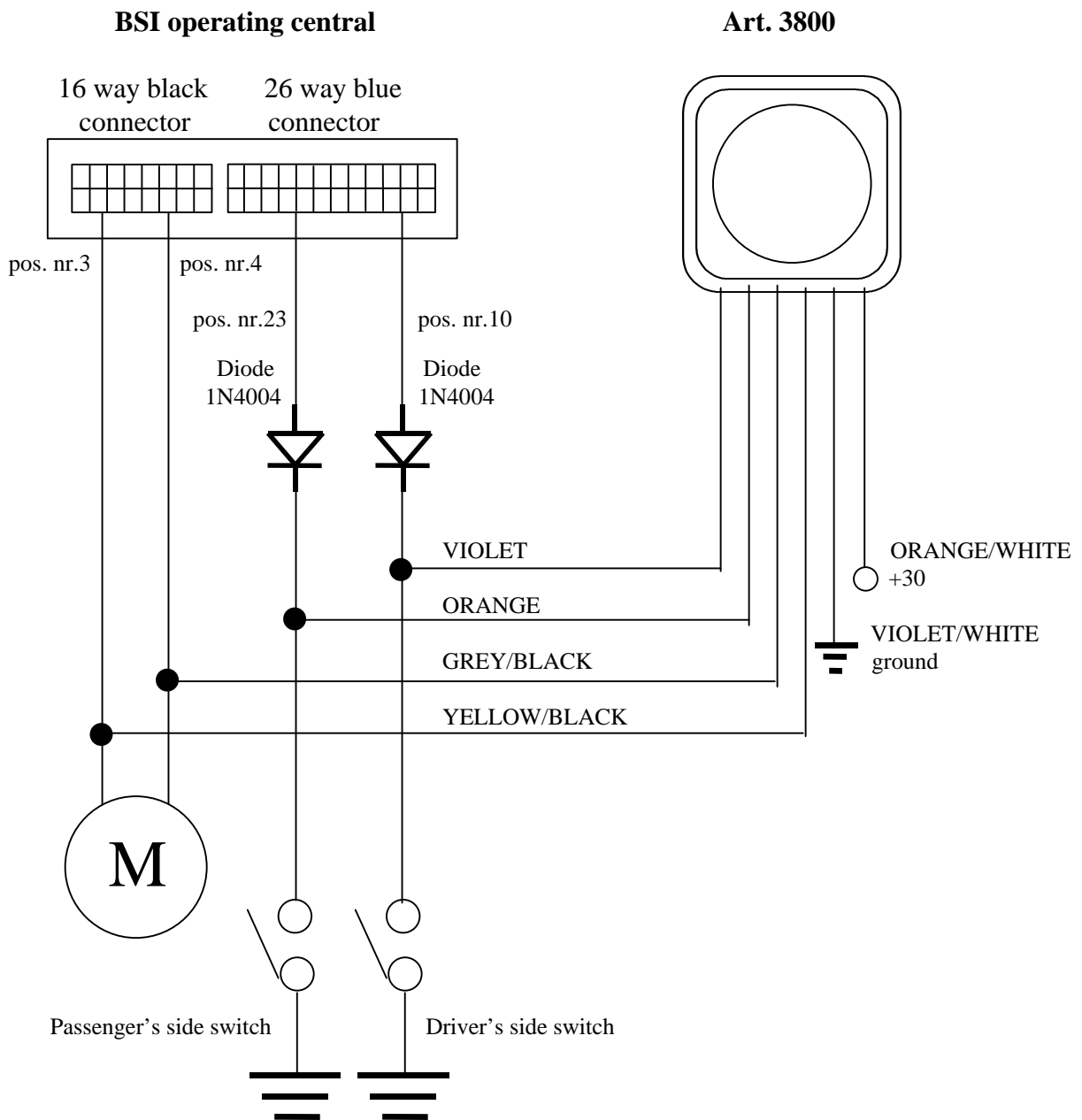

Note: This information is not binding, therefore it must be considered only an example for installation purposes that must be executed as per the instructions given on the product installation manual.

cixs202gbdtd.doc



CAR SECURITY

SPECIFIC VEHICLE ALARM FITTING INSTRUCTIONS

REV. 00

www.cobra.it

FITTING DIAGRAM N° 113

Diagram for windows connection on
CITROEN XSARA 2 year 2002

Diagram for windows locking using the BROWN/WHITE wire of the autodriven Bridge serie antithefts.

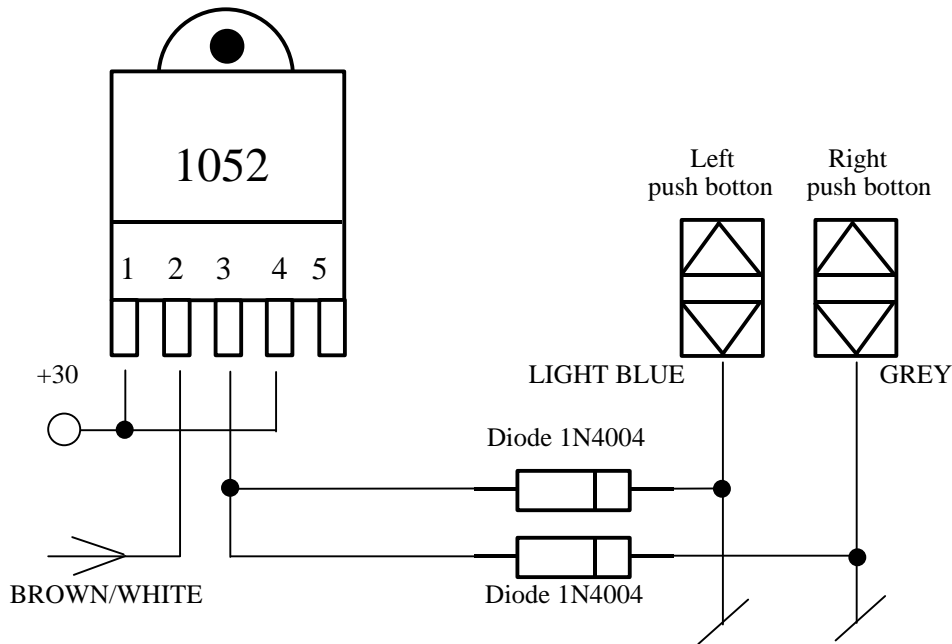

Diagram for windows locking using the BROWN wire of the no autodriven Bridge serie, 3100 e 3800 antithefts.

