



CAR SECURITY

SPECIFIC VEHICLE ALARM FITTING INSTRUCTIONS

REV. 01

www.cobra.it

MAKE

CITROEN

MOD.

XSARA 2

YEAR.

01 →

PETROL
DIESEL

ALARM/SIREN POSITION

Position the compact alarms and the sirens behind the driver's side headlamp. To do that it is suggested to take off the air filter.

CENTRAL UNIT POSITION

Position the modular systems and the modules under the dashboard, driver's side.

POWER SUPPLY

+ **30**: connect to the general supply wire of the fuse box.
- **31**: connect with a cable terminal directly to the car body.

IGNITION WIRE

+ **15/54**: connect to the wire coming out of the 3A fuse (to insert) foreseen as supply for additional accessories located in the shunting box placed on the side of the battery.

DIRECTION INDICATORS

Connect to the wires at the positions nr.14 and nr.15 in the 16 way black connector coming out of the (BSI) accessories operating central located under the fuse box.

ELECTRIC WINDOWS

Positive control signal

Front window, driver's side:

connect to the GREY wire marked nr. 6010 located at the position nr. 4 of the window control switch, driver's side.

Front window, passenger's side:

cut the wire marked nr. 6061, at the position nr. 5, of the window control switch, passenger's side.

For the connection to the driver's side front window, it is necessary to refer to the **diagram nr. 68**.

CENTRAL DOORS LOCKING

Original door motor control signal

For antithefts of the Bridge serie, refer to the **diagram nr.112**, for antithefts of the 3100 serie refer to the **diagram nr.112A**.

IMMOBILISATION POINT

Gasoil pump

Cut the wire marked nr. 1201 located at the E6 position, in the 46 way black connector, placed in the lower part of the fuse box, in the engine compartment, in correspondence of the fuse nr. 52.

STARTER

50: Cut the WHITE wire located in the wiring harness coming out of the connector of the ignition key.

BONNET SWITCH

Install an additional switch on the front headlamp support plate, driver's side. It is necessary to bore also the plastic cover.

DOORS AND BOOT SWITCH

Connect to the wire at the position nr. 14, of the 26 way blue connector, coming out of the (BSI) accessories operating central located under the fuse box.



CAR SECURITY

SPECIFIC VEHICLE ALARM FITTING INSTRUCTIONS

REV. 01

www.cobra.it

FITTING DIAGRAM N°68

Diagram to make the windows locking with automatism on XSARA 2

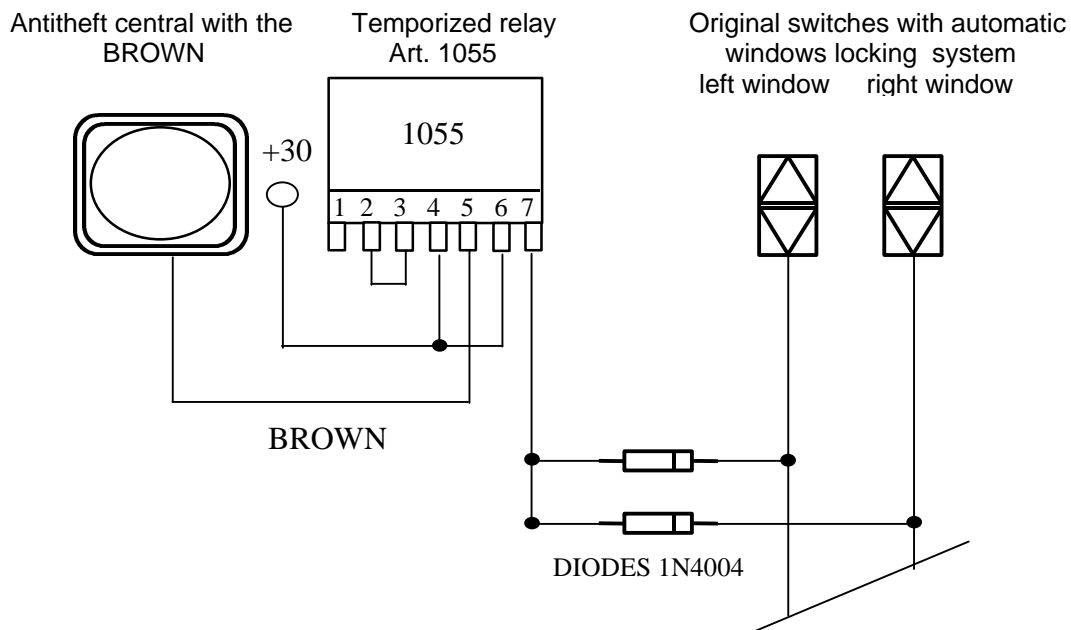
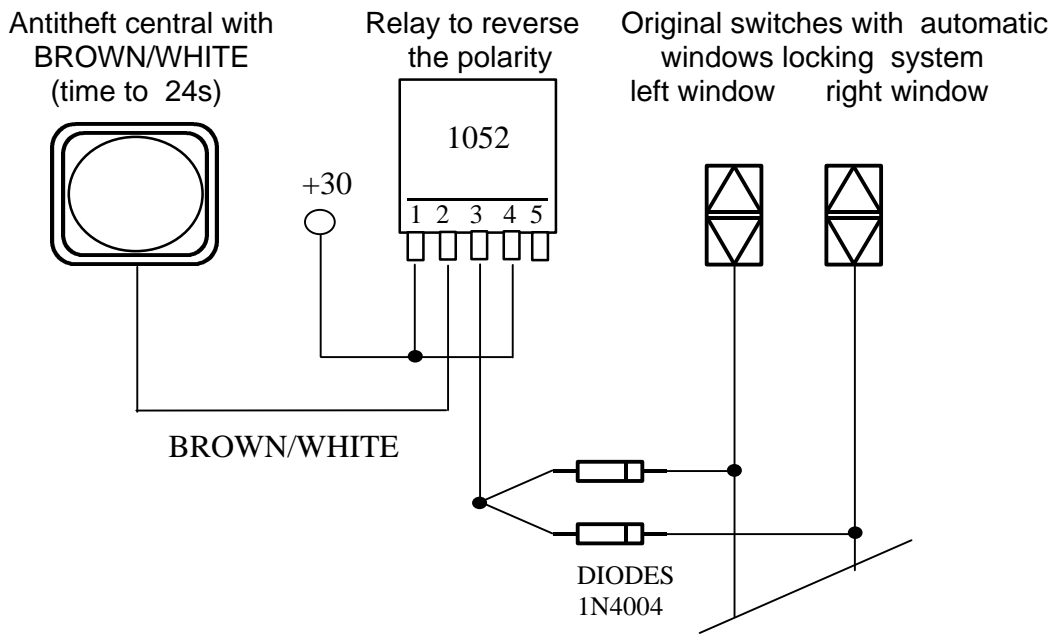

Note:

The above diagrams are to make electric windows locking on vehicles with "MAGIC" system automatism on both the motors.

In any case, if the motor (passenger's side) does not have the automatism, it is necessary to install the art. 2980 module for windows locking.



CAR SECURITY

SPECIFIC VEHICLE ALARM FITTING INSTRUCTIONS

REV. 01

www.cobra.it

FITTING DIAGRAM N°112

Diagram to make the connection of Bridge serie antithefts on
CITROEN XSARA 2

Art. 7918

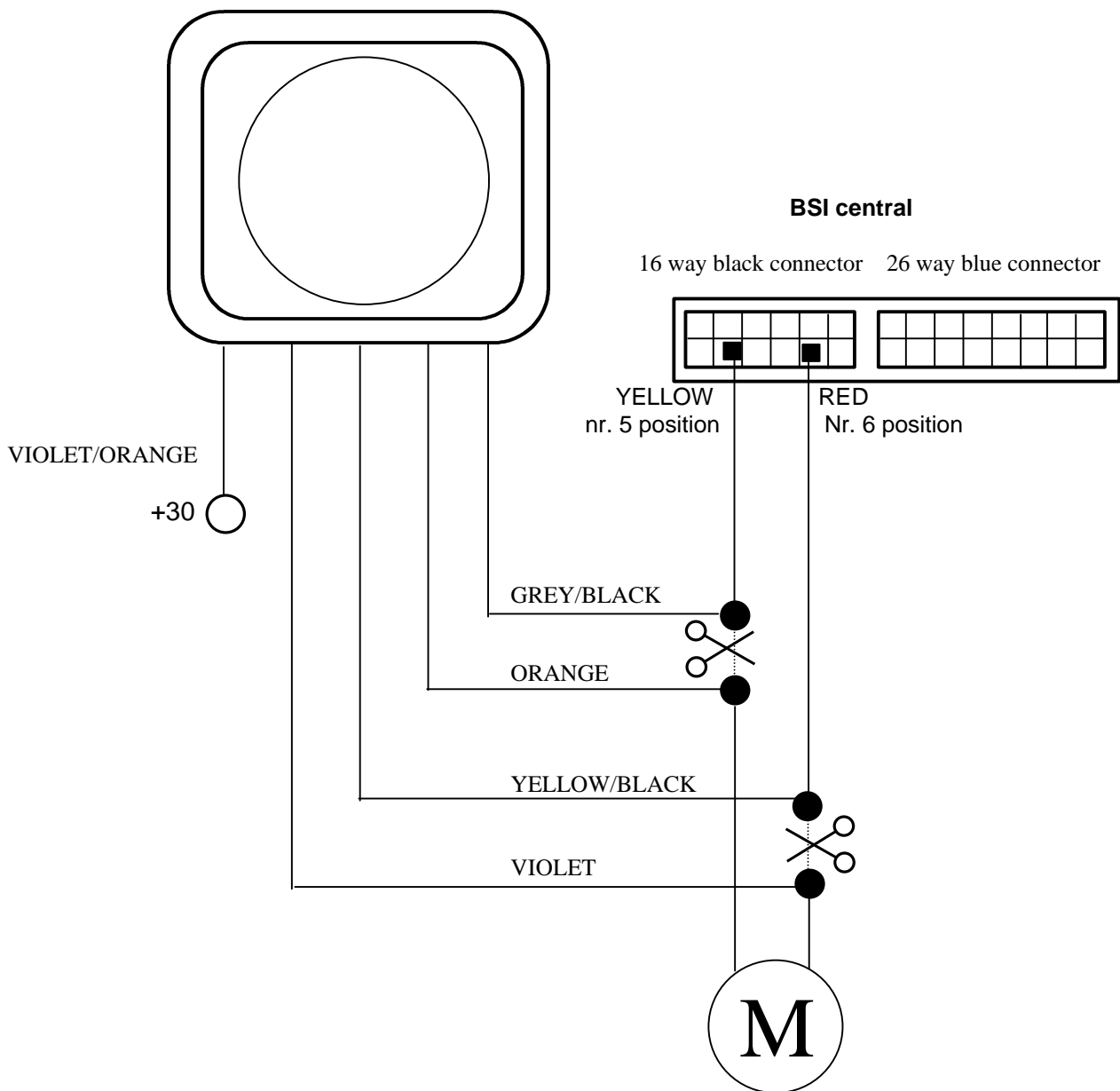



CAR SECURITY

SPECIFIC VEHICLE ALARM FITTING INSTRUCTIONS

REV. 01

www.cobra.it

FITTING DIAGRAM N°112A

Diagram to make connection of 3100 serie antithefts on
CITROEN XSARA 2

Art. 3100

