



## CAR SECURITY

### SPECIFIC VEHICLE ALARM FITTING INSTRUCTIONS

REV. 00

www.cobra.it

MAKE

**CITROEN**

MOD.

**XSARA 2**

YEAR.

**01** →

PETROL   
DIESEL

<b>ALARM/SIREN POSITION</b>	Position the compact alarms and the sirens behind the driver's side headlamp. To do that it is suggested to take off the air filter.
<b>CENTRAL UNIT POSITION</b>	Position the modular systems and the modules under the dashboard, driver's side.
<b>POWER SUPPLY</b>	+ <b>30</b> : connect to the general supply wire of the fuse box. - <b>31</b> : connect with a cable terminal directly to the car body.
<b>IGNITION WIRE</b>	+ <b>15/54</b> : connect to the wire coming out of the 3A fuse (to insert) foreseen as supply for additional accessories located in the shunting box placed on the side of the battery.
<b>DIRECTION INDICATORS</b>	Connect to the wires at the positions nr.14 and nr.15 in the 16 way black connector coming out of the (BSI) accessories operating central located under the fuse box.
<b>ELECTRIC WINDOWS</b>	<b>Positive control signal</b> <b>Front window, driver's side:</b> connect to the GREY wire marked nr. 6010 located at the position nr. 4 of the window control switch, driver's side. <b>Front window, passenger's side:</b> cut the wire marked nr. 6061, at the position nr. 5, of the window control switch, passenger's side. For the connection to the driver's side front window, it is suggested to refer to the <b>diagram nr. 68</b> .
<b>CENTRAL DOORS LOCKING</b>	<b>Negative control signal</b> <b>Wire interruption original control</b> Cut the wire at the position nr. 8 located in the wiring harness coming out of the 26 way blue connector, coming out of the (BSI) accessories operating central placed under the fuse box. Refer to the <b>diagram nr. 71</b> for the antithefts of the Bridge serie or to the <b>diagram nr. 71A</b> for the antithefts of the 3100 serie.
<b>IMMOBILISATION POINT</b>	<b>Gasoil pump</b> Cut the wire marked nr. 1201 located at the E6 position, in the 46 way black connector, placed in the lower part of the fuse box, in the engine compartment, in correspondence of the fuse nr. 52.
<b>STARTER CUT OFF</b>	<b>50</b> : Cut the WHITE wire located in the wiring harness coming out of the connector of the ignition key.
<b>BONNET SWITCH</b>	Install an additional switch on the front headlamp support plate, driver's side. It is necessary to bore also the plastic cover.
<b>DOORS AND BOOT SWITCH</b>	Connect to the wire at the position nr. 14, of the 26 way blue connector, coming out of the (BSI) accessories operating central located under the fuse box.



CAR SECURITY

SPECIFIC VEHICLE ALARM FITTING INSTRUCTIONS

REV. 00

www.cobra.it

FITTING DIAGRAM N° 68

### Diagram to make the windows locking with automatism on XSARA 2

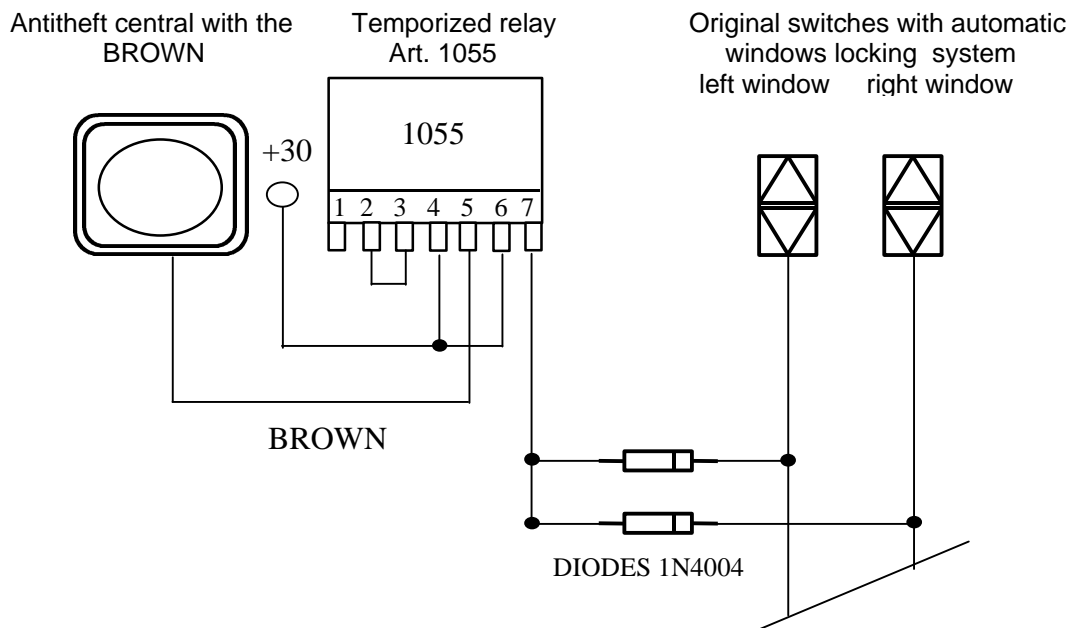
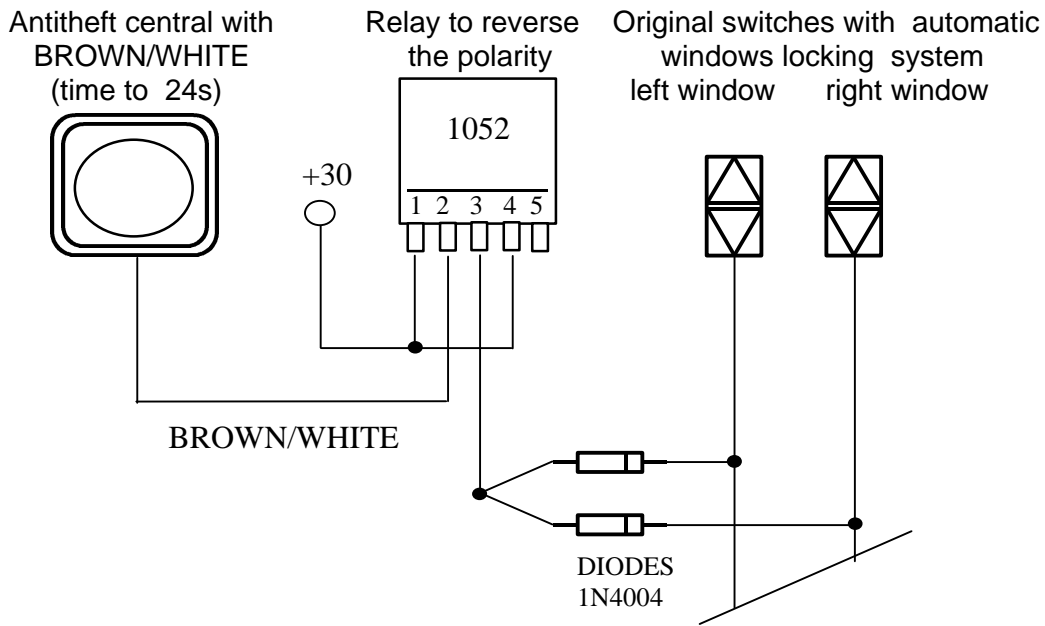

**Note:**

The above diagrams are to make electric windows locking on vehicles with "MAGIC" system automatism on both the motors.

In any case, if the motor (passenger's side) does not have the automatism, it is necessary to install the art. 2980 module for windows locking.



CAR SECURITY

SPECIFIC VEHICLE ALARM FITTING INSTRUCTIONS

REV. 00

www.cobra.it

FITTING DIAGRAM N° 71

To make the central doors locking on  
**CITROEN BERLINGO – EVASION – XSARA 2 mod. 2001**  
(for “Bridge” car alarms)

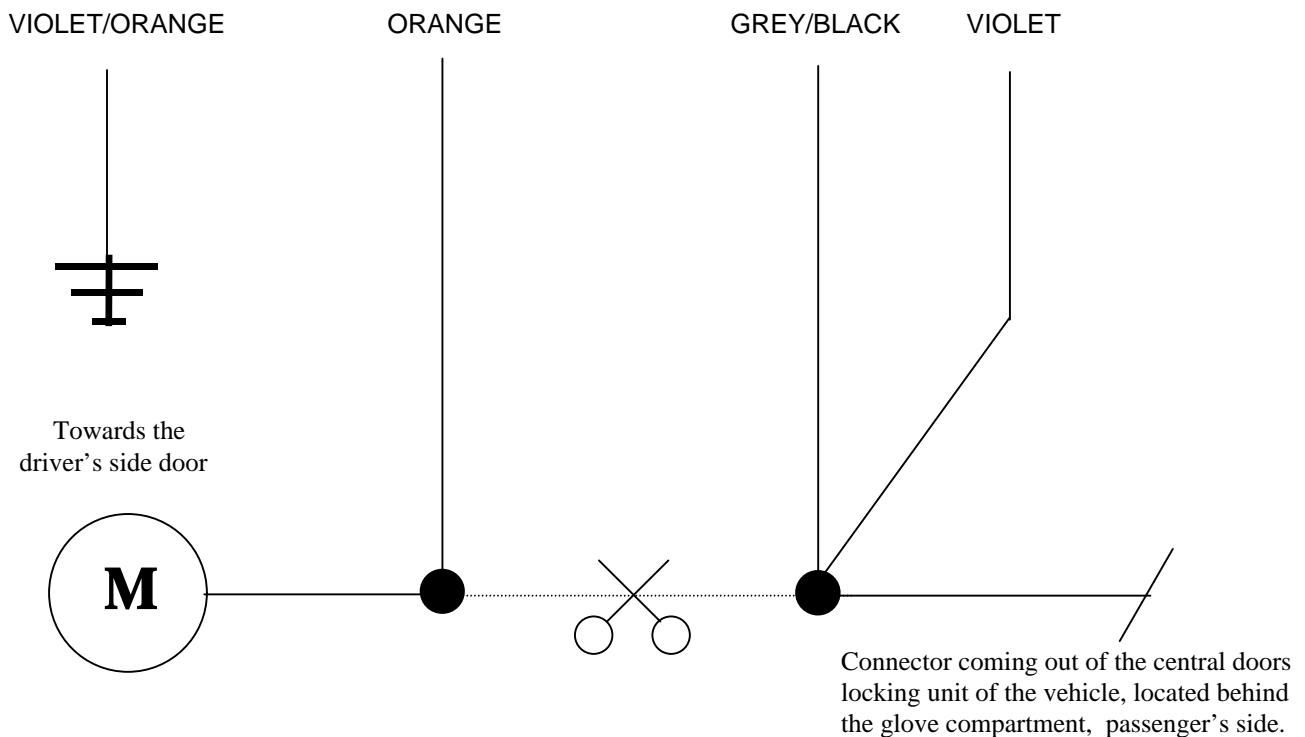

**Note:** The wire indicated in the alarm fitting instructions of Citroen Berlingo, Evasion and Xsara 2 must be interrupted as per the above drawing. Pay attention that the position of the wire that must be interrupted changes as per the vehicle.



CAR SECURITY

SPECIFIC VEHICLE ALARM FITTING INSTRUCTIONS

REV. 00

www.cobra.it

FITTING DIAGRAM N°71A

To make the central doors locking on  
CITROEN BERLINGO – EVASION – XSARA 2 mod. 2001  
(for 3100 serie car alarms)

VIOLET/WHITE  
ORANGE/WHITE

ORANGE

GREY/BLACK

VIOLET

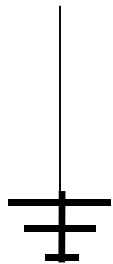

Towards the  
driver's side door

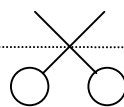
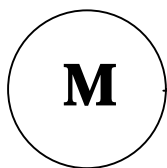

Connector coming out of the central doors  
locking unit of the vehicle, located behind  
the glove compartment, passenger's side.

**Note:** The wire indicated in the alarm fitting instructions of Citroen Berlingo, Evasion and Xsara 2 must be interrupted as per the above drawing. Pay attention that the position of the wire that must be interrupted changes as per the vehicle.