



## CAR SECURITY

### SPECIFIC VEHICLE ALARM FITTING INSTRUCTIONS

REV. 00

www.cobra.it

MAKE

**CHRYSLER**

MOD.

**NEON**

YEAR

**96** →

PETROL   
DIESEL

#### ALARM/SIREN POSITION

Position the compact alarms and the sirens in the engine compartment, under the battery bracket. Pass the cables through the original rubber sleeve located on the panel between the engine compartment and the passenger's compartment.

#### POWER SUPPLY

+ **30**: connect to the general supply wiring at the entrance of the fuse box.  
- **31**: connect with a ring terminal directly to the car body.

#### IGNITION WIRE

+ **15/54**: connect to the 2 mm<sup>2</sup> BLUE wire located in the wiring harness under the steering column.

#### DIRECTION INDICATORS

Connect to the 1,5 mm<sup>2</sup> BROWN, BROWN/RED, GREEN and GREEN/RED wires located in the wiring harness under the steering column.

#### ELECTRIC WINDOWS

##### Positive control signal

##### Front window, driver's side:

cut the 2 mm<sup>2</sup> PINK/BLACK wire, inside the driver's side door.

##### Front window, passenger's side:

cut the 2 mm<sup>2</sup> ORANGE/BLACK wire located in the wiring harness coming out of the driver's side door.

#### CENTRAL DOORS LOCKING

##### Positive control signal

Make reference to the **diagram nr. 20** for antithefts of the serie Bridge or to the **diagram nr.20A** for antithefts of the serie 3100.

#### IMMOBILISATION POINT

##### Fuel pump

Cut the 1,5 mm<sup>2</sup> GREEN/WHITE wire located in the wiring harness behind the sill cover, driver's side.

#### STARTER

+**50**: Cut the YELLOW/RED wire located near the clutch pedal.

#### BONNET SWITCH

Install an additional switch on the front headlamp support plate, near the original bonnet bumper rubber.

#### DOORS SWITCH

Connect to the 1 mm<sup>2</sup> YELLOW wire located in the wiring harness behind the sill cover, driver's side.



CAR SECURITY

SPECIFIC VEHICLE ALARM FITTING INSTRUCTIONS

REV. 00

www.cobra.it

FITTING DIAGRAM N°20

Diagram to make the central doors locking with antitheft of the Serie Bridge

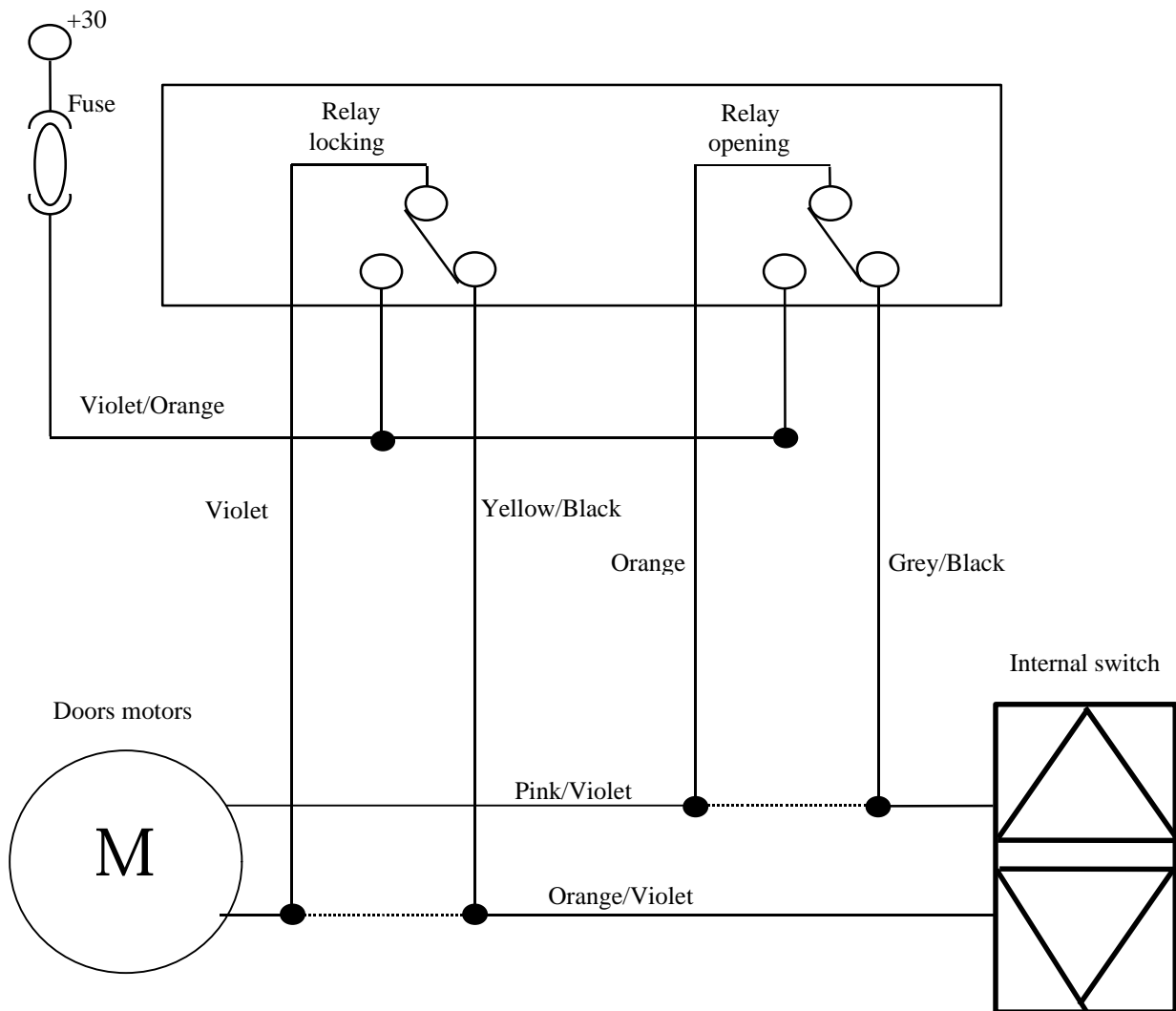

Wiring harness located behind the driver's side glove compartment.



CAR SECURITY

SPECIFIC VEHICLE ALARM FITTING INSTRUCTIONS

REV. 00

www.cobra.it

FITTING DIAGRAM N°20A

Diagram to make the central doors locking with antitheft of the Serie 3100

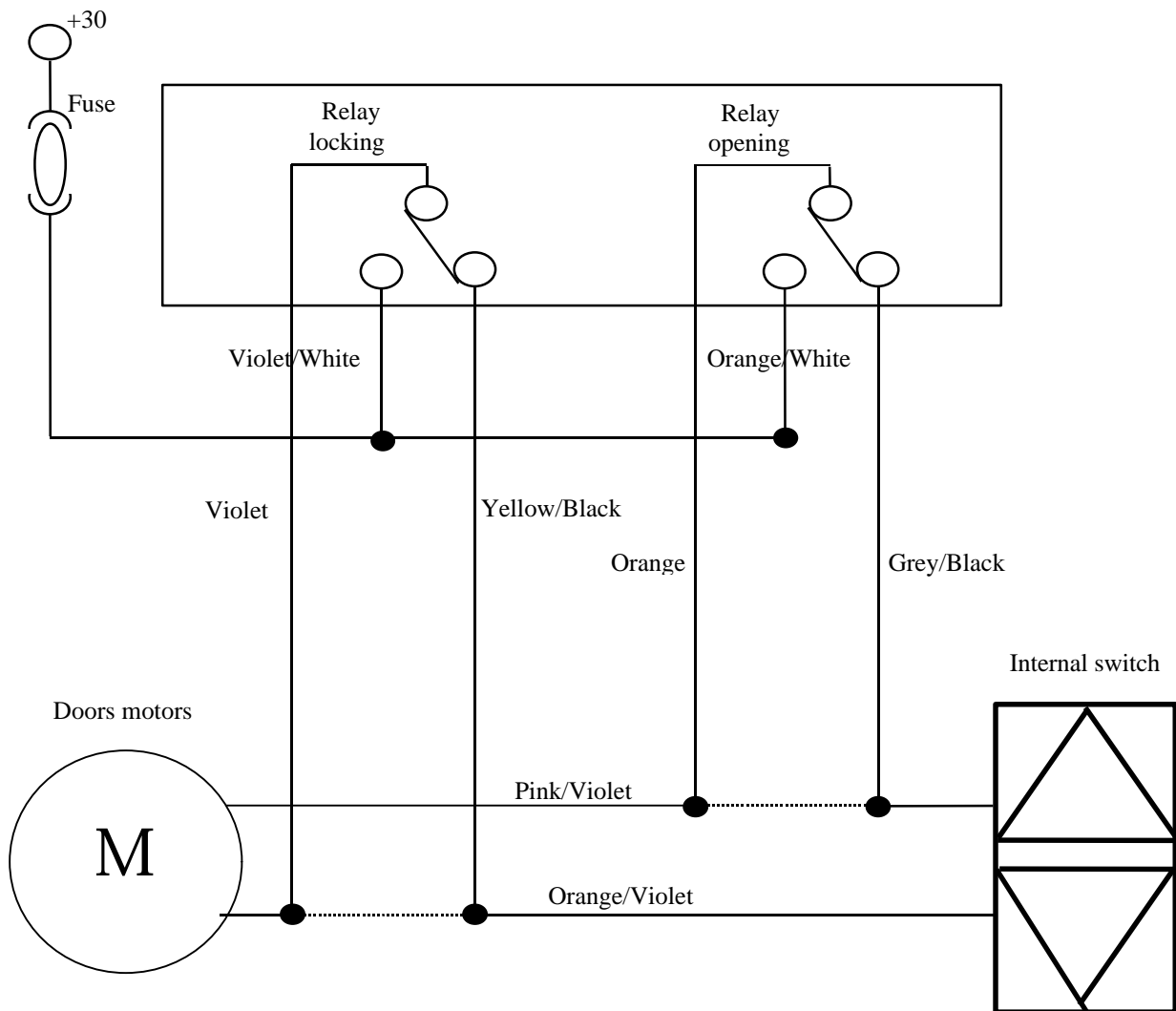

Wiring harness located behind the driver's side glove compartment.