

# Attention!!

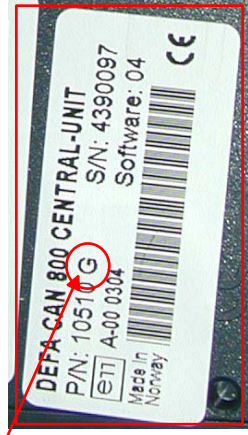

|                          |                                  |           |
|--------------------------|----------------------------------|-----------|
| AUTHOR:<br>Knut O. Malme | REVISION / DATE:<br>PA1 / 041109 | APPROVAL: |
|--------------------------|----------------------------------|-----------|

**If you are going to install a G-version of the central unit; please read this page.**  
**If not; skip this page.**



Some F alarm central units have entered the marked as G-versions. Open the G central unit to decide the real version of the central unit.

Have a look at the marking of the resistors on the picture below.  
Marking:

511 => F-version. ~~Do not install this central unit in the Volvo V50 2005.~~  
332 => G-version. Follow the ~~installation~~ description for the G-version on the following pages.

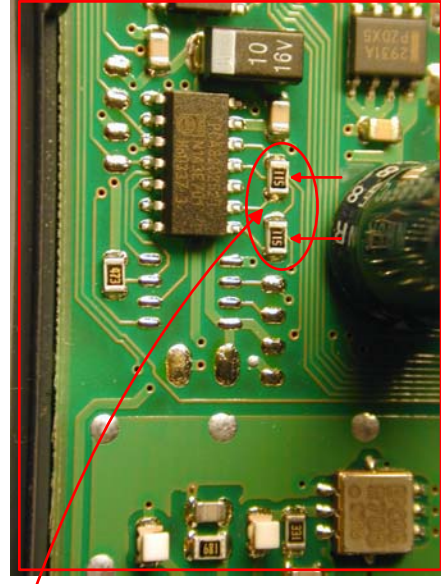

For more information read Technical Message No. 11. 2004. ([www.defa.com](http://www.defa.com)).

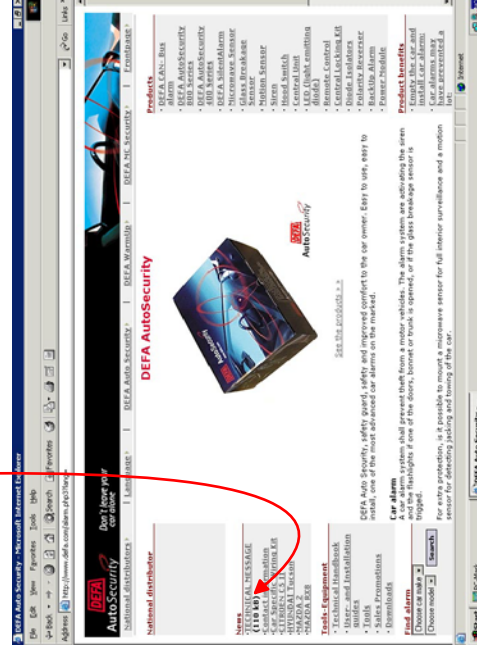

**NB !** This installation diagram must only be used as a guideline for the installation. Equipment delivered with the car varies considerably from model to model and from market to market. Before starting the installation, be sure to check carefully the original diagram from the car manufacturer. DEFA AS is not liable to compensate for possible damages that may occur due to faulty or insufficient installation manuals.

**NOTE:**  
**SIDE DIRECTION INDICATORS ARE NOT CONNECTED!**

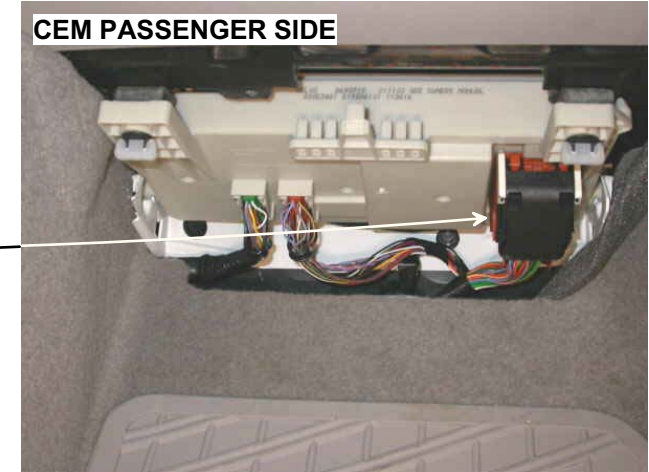
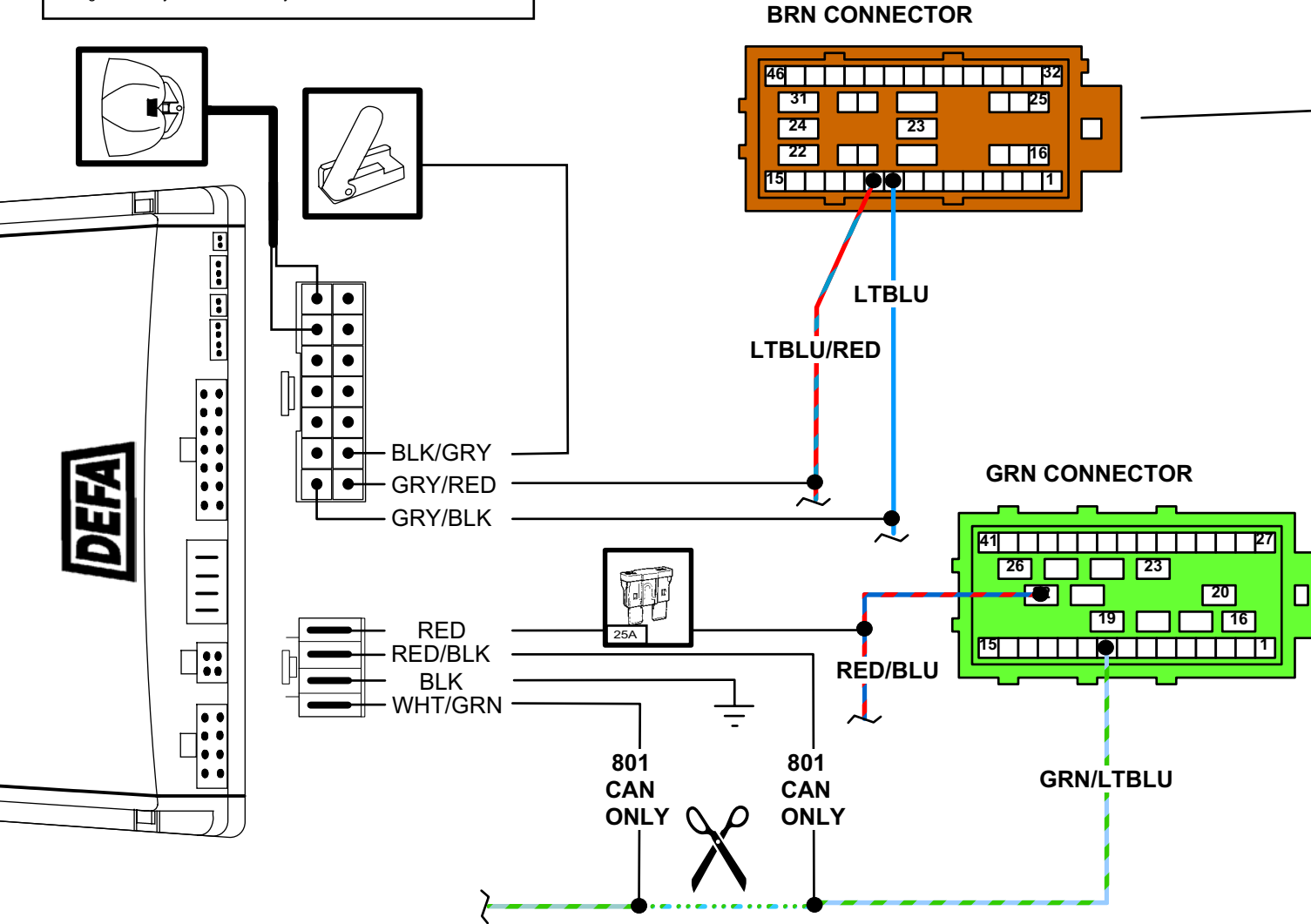

**REQUIRED:**

- Central unit rev: G →
- Minimum Required SoftWare 04-6
- Resistors (2 x 2k2 ohm (1 x 600640))

Date : 2004.11.08  
Rev : A  
Page: 1 of 3

**NOTE!!!**

**HOW TO SYNCHRONIZE CAN INTERFACE:**

- 1) INSERT 25A FUSE => LED WILL START FLICKERING
- 2) TURN ON IGNITION => LED WILL STOP FLICKERING WITHIN 30 SECONDS  
THE ALARM IS NOW SYNCHRONIZED

**TO ARM WITHOUT SENSORS:**

TURN ON AND OFF IGNITION FOR LESS THAN TWO SECONDS.  
PRESS LOCK-BUTTON ON REMOTE ONCE.

