

NB ! This installation diagram must only be used as a guideline for the installation. Equipment delivered with the car varies considerably from model to model and from market to market. Before starting the installation, be sure to check carefully the original diagram from the car manufacturer. DEFA A.S is not liable to compensate for possible damages that may occur due to faulty or insufficient installation manuals.

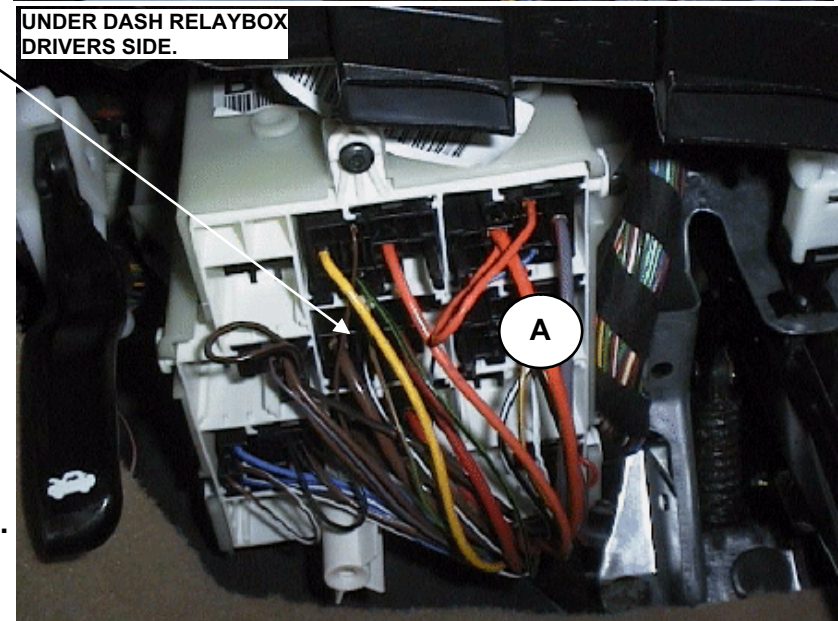
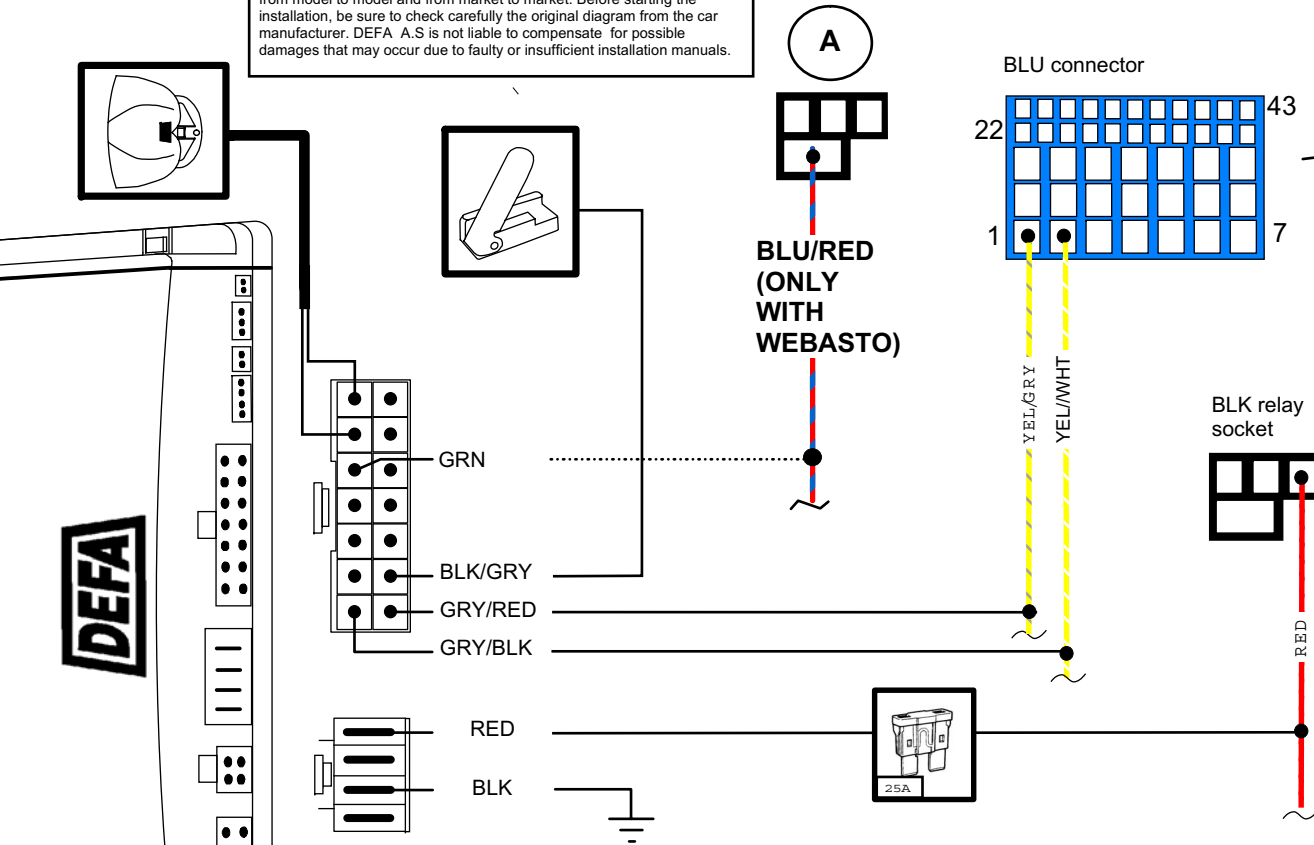

IF THE VEHICLE IS EQUIPPED WITH A WEBASTO SYSTEM, CONNECT P4-10 (USE 600526) TO AN ANALOG IGNITION SIGNAL, AND THEN USE SPECIAL SOFTWARE FOR SAAB 9-5 WITH WEBASTO. SEE www.defa.com/flash.

REQUIRED:
 - Minimum Required Central Unit rev: H
 - Minimum Required SoftWare: 02
 - Resistors (2 x 2k2 ohm (1 x 600640, including 4 resistors))

Date : 2006.04.06
 Rev : C
 Page: 1 of 3

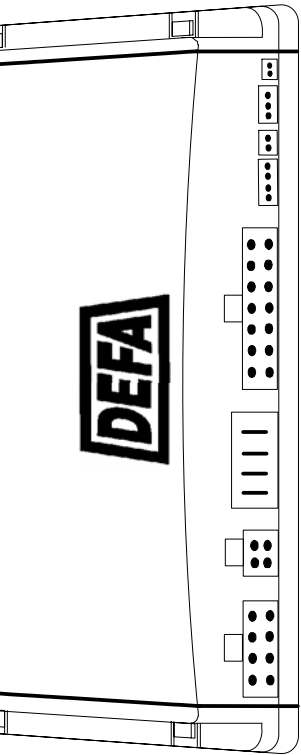

CONNECTOR P1

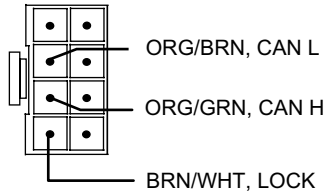

2k2 ohm

2k2 ohm

