

NB! This installation diagram must only be used as a guideline for the installation. Equipment delivered with the car varies considerably from model to model and from market to market. Before starting the installation, be sure to check carefully the original diagram from the car manufacturer. DEFA A.S is not liable to compensate for possible damages that may occur due to faulty or insufficient installation manuals.

NOTE!!!

HOW TO SYNCHRONIZE CAN INTERFACE:

- 1) **INSERT 25A FUSE => LED WILL START FLICKERING**
 - 2) **PRESS UNLOCK BUTTON ON REMOTE SEVERAL TIMES => LED WILL STOP FLICKERING WITHIN 60 SECONDS**
- THE ALARM IS NOW SYNCHRONIZED**

TO ARM WITHOUT SENSORS:

TURN ON AND OFF IGNITION FOR LESS THAN TWO SECONDS.
PRESS ARM-BUTTON ON REMOTE ONCE.

NOTE:
DISARM THE ALARM BEFORE USING
THE TRUNKRELEASE BUTTON ON ORIGINAL REMOTE!

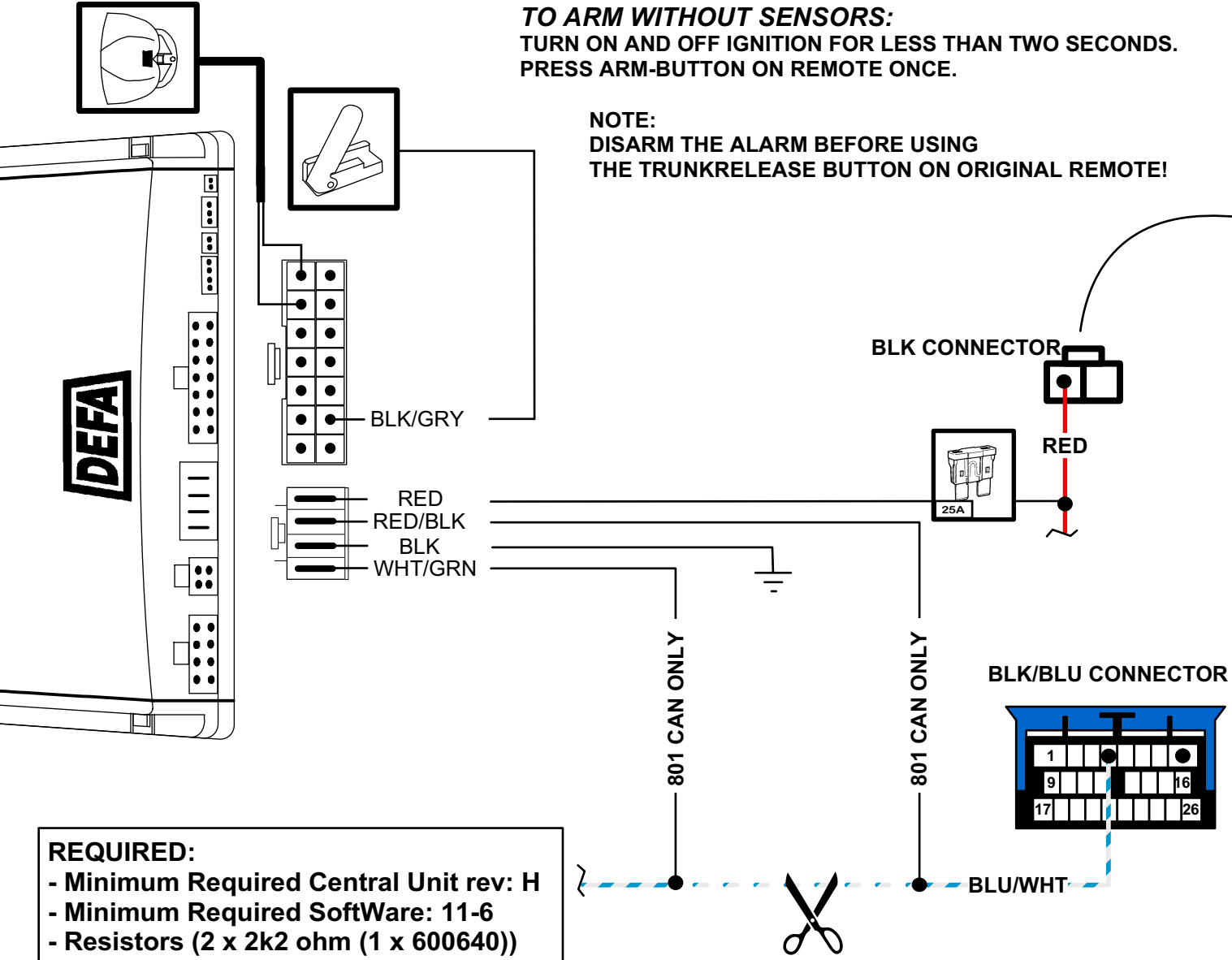

REQUIRED:

- Minimum Required Central Unit rev: H
- Minimum Required SoftWare: 11-6
- Resistors (2 x 2k2 ohm (1 x 600640))

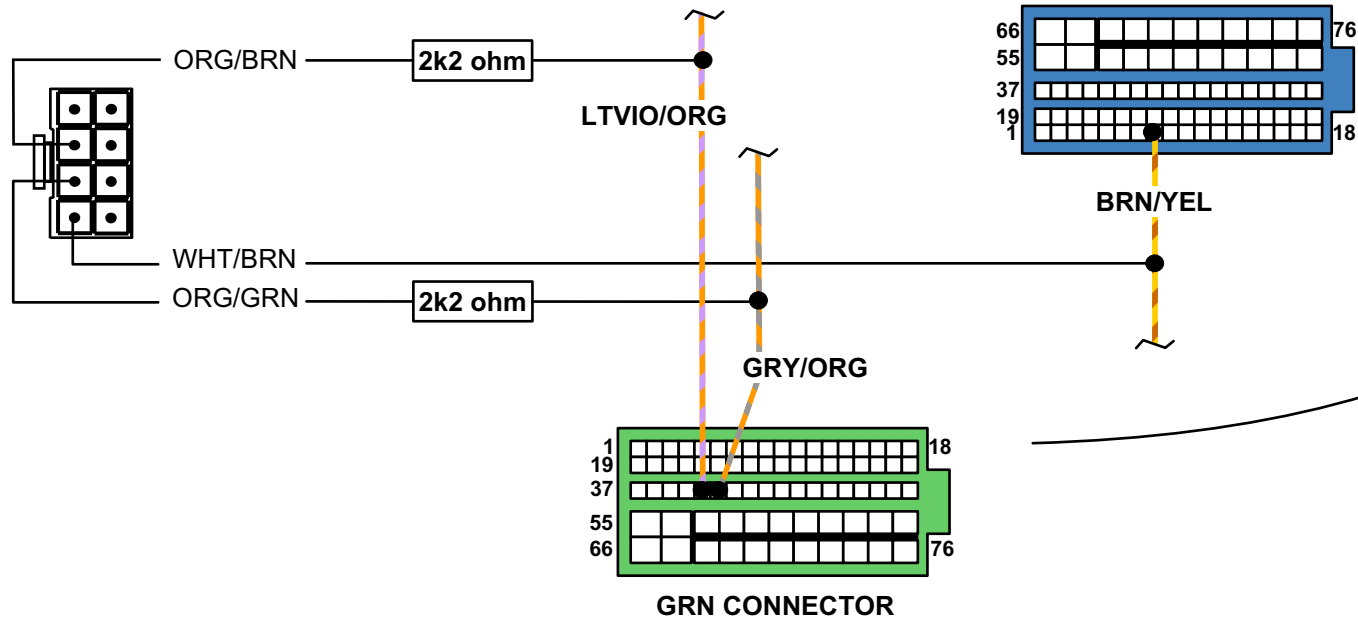
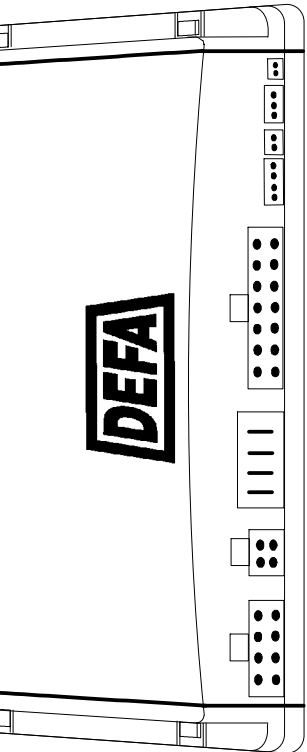

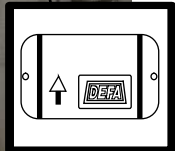
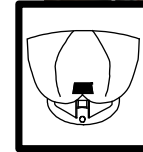
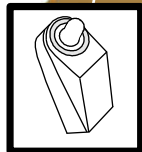
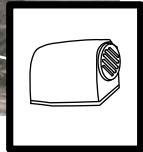

Level nr. 3.

